

EQ-CM01T

1/2hp Tilting Chisel Mortiser Instruction



Specification

Chisel Capacity : 6~16 mm (1/4"~5/8")

Max. Chisel Stroke : 228 mm

Distance from Fence to
Center Chisel : 102mm

Distance from Center Chisel
to Table : 152~228 mm

Chuck Capacity : 13 mm (1/2 ")

Speed of Spindle : 60 HZ/1720 RPM

Size of Table : 343 x 230 mm

Size of Base : 360 x 265 mm

Motor : 0.37 KW (1/2 HP)

Overall Height : 736 mm

Net Weight : 46KGS

Gross Weight : 48KGS

Packing size : (D x W x H): 410 x 380 x 680 mm

SAFETY RULES

READ CAREFULLY BEFORE OPERATING THE MACHINE

1. Learn the machine's applications and limitations, as well as the specific potential hazards particular to this machine. Follow available safety instructions and safety rules carefully.
2. Keep working area clean and be sure adequate lighting is available.
3. Do not wear loose clothing, gloves, bracelets, necklaces, or ornaments, Wear face, eye, ear, respiratory and body protection devices, as indicated for the operation or environment.
4. Keep hands well away from chuck, bit and all moving parts. Do not clear chips and sawdust away with hands. Use a brush.
5. Make sure the bit is moving at operation speed before mortising.
6. Do not push the chisel to hard. The bit and chisel will perform better and be safer working at the rate for which it was designed.
7. Whenever possible use a dust collector with shaving hood to minimize health hazards.
8. Never leave the machine with the power on.
9. Keep children away. Make sure that visitors are kept at a safe distance from the work area.

10. Use recommended speed mortising accessory, and workpiece material.
11. Never stand on tool. Serious injury could occur if the tool is tipped or if the cutting tool is unintentionally contacted.
12. Be sure bit and chisel are securely locked in the machine.
13. Use suitable support if stock does not have a flat surface.
14. Do not force the machine . It will do the job better and be safer at a rate for which it was designed.
15. Keep guards in place and in working order. If a guard must be removed for maintenance or cleaning make sure it is properly attached before using the tool again.
16. Be sure that key and adjusting wrenches have been removed before turning power on.
17. Use only accessories designed for the machine.
18. Make sure tool is properly grounded. If tool is equipped with three-prong plug, it should be plugged into a three-pole electrical receptacle. Never remove the third prong
19. Always disconnect tool before servicing and when changing accessories such as bit and chisel.
20. Make sure that switch is in "OFF" position before plugging in cord.
21. Hold material firmly against the table.
22. Use ONLY recommended accessories. Use of accessories NOT recommended by General International may result in a risk of injury.

23. During design & construction of this machine in addition to local standards and some relative standards. **Do not use on drilling function and explosive material (e.g. aluminum, magnesium and their alloys).**

24. **Stand on proper position for operation.**

Please stand in front of machine for operation.

25. Disposing wasted material shall obey the local regulation and be deeply careful.

26. Workshop of user shall be with the fire extinguisher or other devices according to the local safety regulations and be deeply careful.

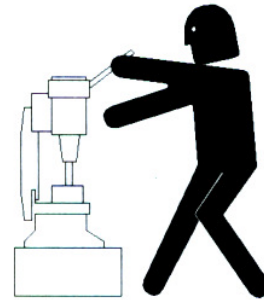

27. **Make sure machine is disconnected from power supply:**

Make sure machine is disconnected from power supply before started the normal maintenance and service, adjustment, or repairing.

28. Never open the protective cover or the machine door while the machine is running. Never attempt to change the settings of all protective devices without consulting us.

29. The noise level of this machine is testing on continuous running.

a) The measurement of emission sound pressure level is defined according to European Standard, ISO3746.

b) A-weighted sound pressure level measuring under no load at operation position is 71.4dB(A), and under load at operation position is 80.7dB(A).

! 30. Watch what you are doing. Do not operate machine when you are tired to avoid stabbing hazard. Please wear goggle protection and mouth-muffle to operation. For the warning labels on the machine, refer afterward figures--



31. We recommend that should be clamping well by vise before chiseling your workpiece.

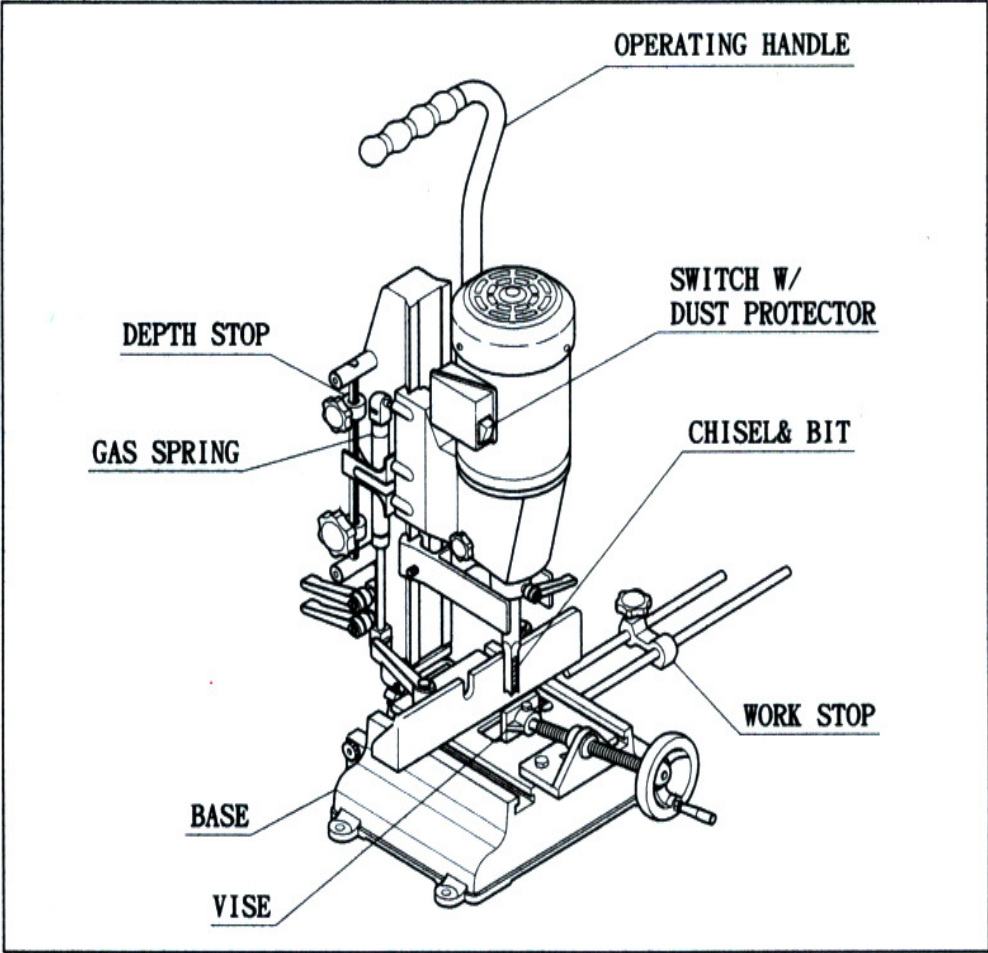

WARNING!

CAREFULLY READ AND UNDERSTAND YOUR OWNER'S MANUAL BEFORE STARTING WORK OPERATIONS!

WARNING!

MACHINE MUST BE PROPERLY GROUNDED AT ALL TIMES TO AVOID ELECTRIC SHOCK TO THE WORK OPERATOR!

INSTALLATION AND SETUP

(4) Holes have been designed at the base of the cast iron to conveniently bolt and fasten your Mortiser to a workbench (optional stand), or a solid work surface. Place your machine on the worktable; use a marker to indicate the areas where the holes must be drilled. Properly fasten and bolt to surface. (Bolts and nuts not provided)

Note: Work area must provide enough space on both sides of the machine to allow movement for the work operator and clearance for long work materials. Avoid installing the machine in a small or dark work area, no obstacles should interfere when work operations are being performed.

CHISEL & BIT INSTALLATION / REPLACEMENT (FIG.2)

1. Gently loosen lock knob; install your chisel and bit as illustrated. Chisel must be positioned and pushed up against the bushing and into the slot, set the slot to the right or the left this will permit loose chips to unload from chisel when cutting mortises.
2. Gently re-tighten the lock knob in order to hold in position.
3. Loosen chuck and move the bit into the chuck in order to adjust the position of the bit.
4. The lower end of the bit must jut out from below the chisel between 1/16" to 3/16"; according to the workpiece and the work operations that need to be performed.
5. Re-tighten the chuck.

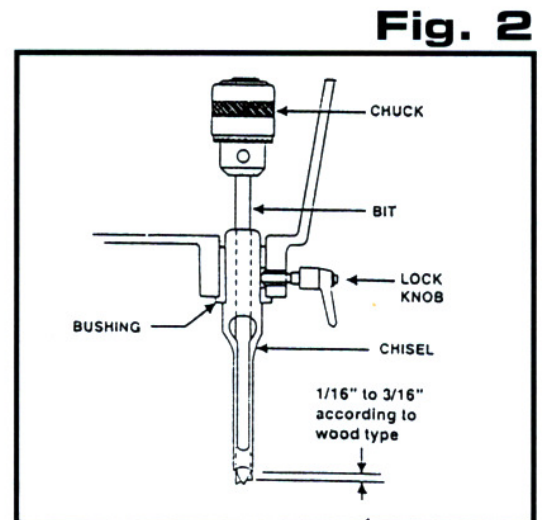

MORTISING

To prevent burning at the tip of the bit; a fast and steady feed rate is required. Consider the type of material before feeding, the machine may stall or slow down if the feed rate is too fast. Perform practice cuts before starting work operations, various work material require different feedings.

To avoid overheating or rupture to the chisel or bit; do not position the slot against the blind end of the mortise; this will prevent the chips to unload from the chisel.

WORK OPERATIONS

1. Depth stop must be set to the required depth of cut (Fig.3).
2. Place your workpiece on table; lock into position using the vise clamp. Turn handwheel in order to move the table forward or backwards. Adjust table in accordance with the workpiece to be mortised.
3. Adjust the stops according to the length of cut required (Fig.4).
4. Press the "On" switch; steadily and firmly feed the chisel and bit into the workpiece by pulling down on the operating handle.
5. To prevent burning at the tip of the bit; a fast and steady feed rate is required. Consider the type of material before feeding, the machine may stall or slow down if the feed rate is too fast.

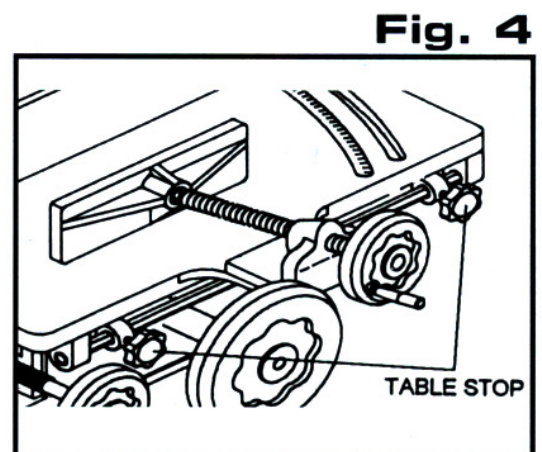
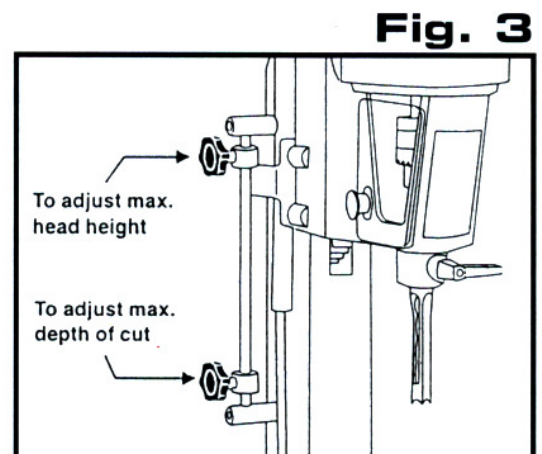

6. Perform practice cuts before starting work operations, various work material require different feedings
7. Complete the first mortising cut; carry the workpiece towards the proper direction of the chisel slot to permit chips to unload clearly. Move the workpiece in order for the chisel slot to release chips into the already cut part of the mortise (Fig.5).
8. To permit chips to unload while mortising deep cuts; the cuts must be carried out in several steps of 1" each cut. Place a piece of scrap wood under the back end to support the workpiece, this will prevent breakage at the back end.

ATTENTION!

NEVER ATTEMPT TO LEAVE THE MACHINE RUNNING UNATTENDED!

WARNING!

ALWAYS DISCONNECT THE MACHINE FROM THE POWER SOURCE WHEN NOT IN USE!

SHARPENING BIT AND CHISEL

To ensure perfect performance and accurate work, it is necessary to keep bit and chisel sharp at all times. Dull bit or chisel can cause overheating and breakage resulting in unsatisfactory and inaccurate results. If chisel and bit are badly worn and become difficult to sharpen, they must be replaced immediately.

To sharpen: trace the original shapes and curves of the bit with a small smooth filer. To restore sharpness, file the inside edge of the spur, the sides of the brad point and the cutting edge inwards towards the flutes of the bit (Fig.6). Never attempt to sharpen the outside edge of the spur this will affect the diameter and performance of the bit.

Chisel should always be sharpened with a proper size mortise chisel cutter. Verify the dullness of the chisel, two or three turns of the cutter in a carpenter's hand brace should be enough to sharpen the chisel. (Fig.7)

Relieve the inner corners of the chisel with a small triangular smooth filer. Remove any particles from the outside of the chisel with a fine oilstone. (Fig 8)

Chisel and bit will need to be replaced after a long period of use. Worn out tools will result in inaccurate and unsatisfactory work operations.

WARNING!

DISCONNECT MACHINE FROM POWER SOURCE BEFORE PERFORMING ANY REPAIRS OR ADJUSTMENTS! FAILURE TO COMPLY CAN CAUSE SERIOUS DAMAGES TO THE WORK OPERATOR AND THE MACHINE!

Fig. 5

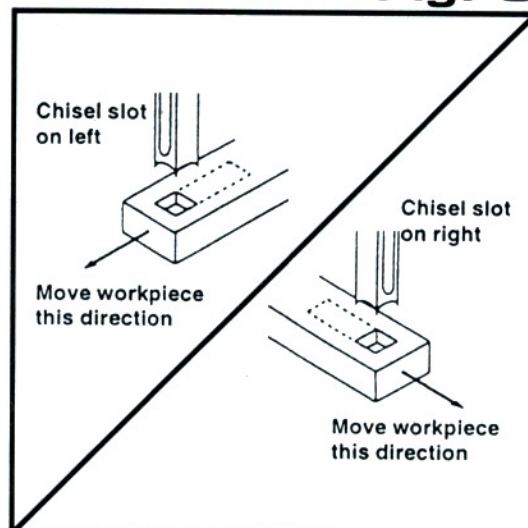

Fig. 6

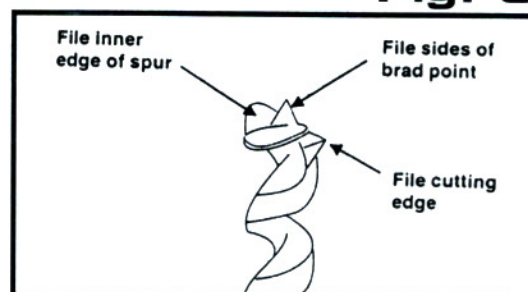

Fig. 7

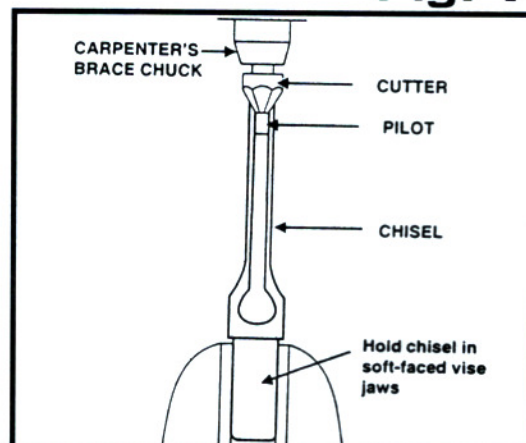
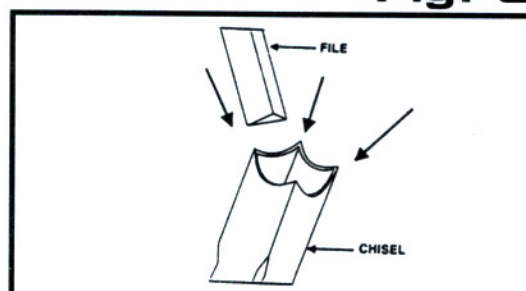

Fig. 8



Tilting & Swiveling

EXTEND WORKING CAPACITY ADJUSTMENT

1. Loosen two ratchet handles (B). (Fig 9-1)
2. Minor tighten ratchet handle (C) to split column a little bit.
3. Hold and lift the head with hands about 3" at proper position. (Fig 10-1)
4. Loosen ratchet handle (C) and tighten ratchet handles(B).

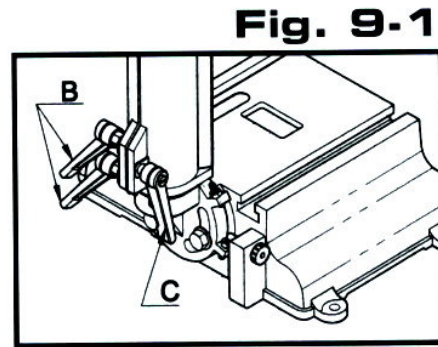

HEAD SWIVELING

1. Remove chisel before swiveling head. (Fig 9-1)
2. Loosen two ratchet handles (B).
3. Screw ratchet handle (C) tightly for swiveling Head to 180°.
4. Loosen ratchet handle (C) and tighten ratchet handles (B).

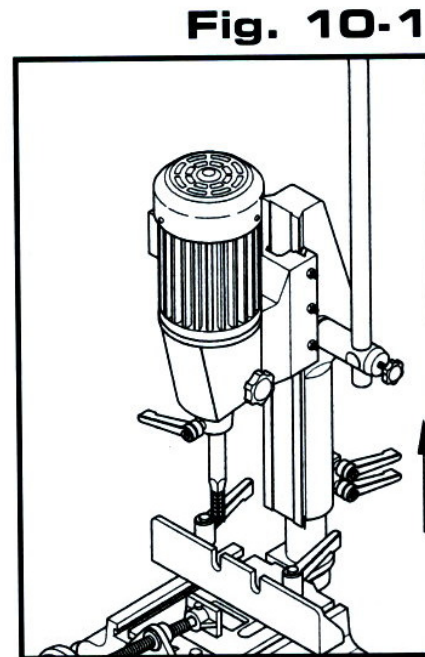

HEAD TILTING

1. Hold the head and loosen two screws (A). (Fig 11-1)
2. Pull the pin (B) outward to move the head to desired Angle.
3. Adjust screws (C) and (D) while angle is not accurate During period. (Fig 11-1,12-1)

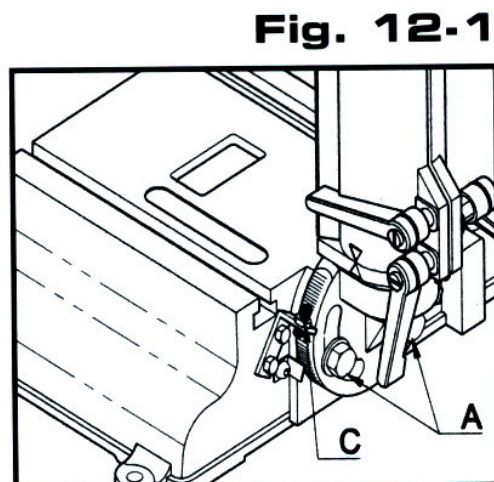
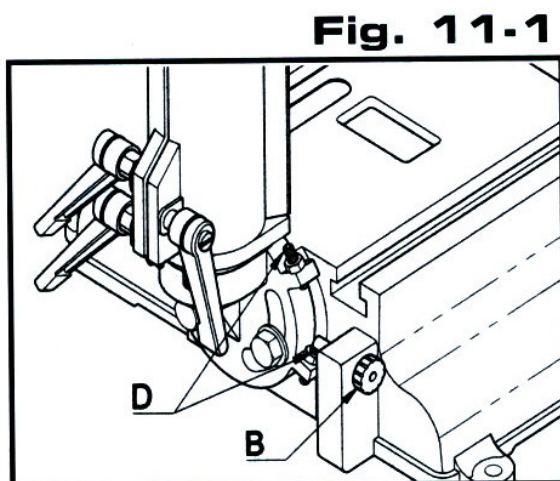

DIAGRAM

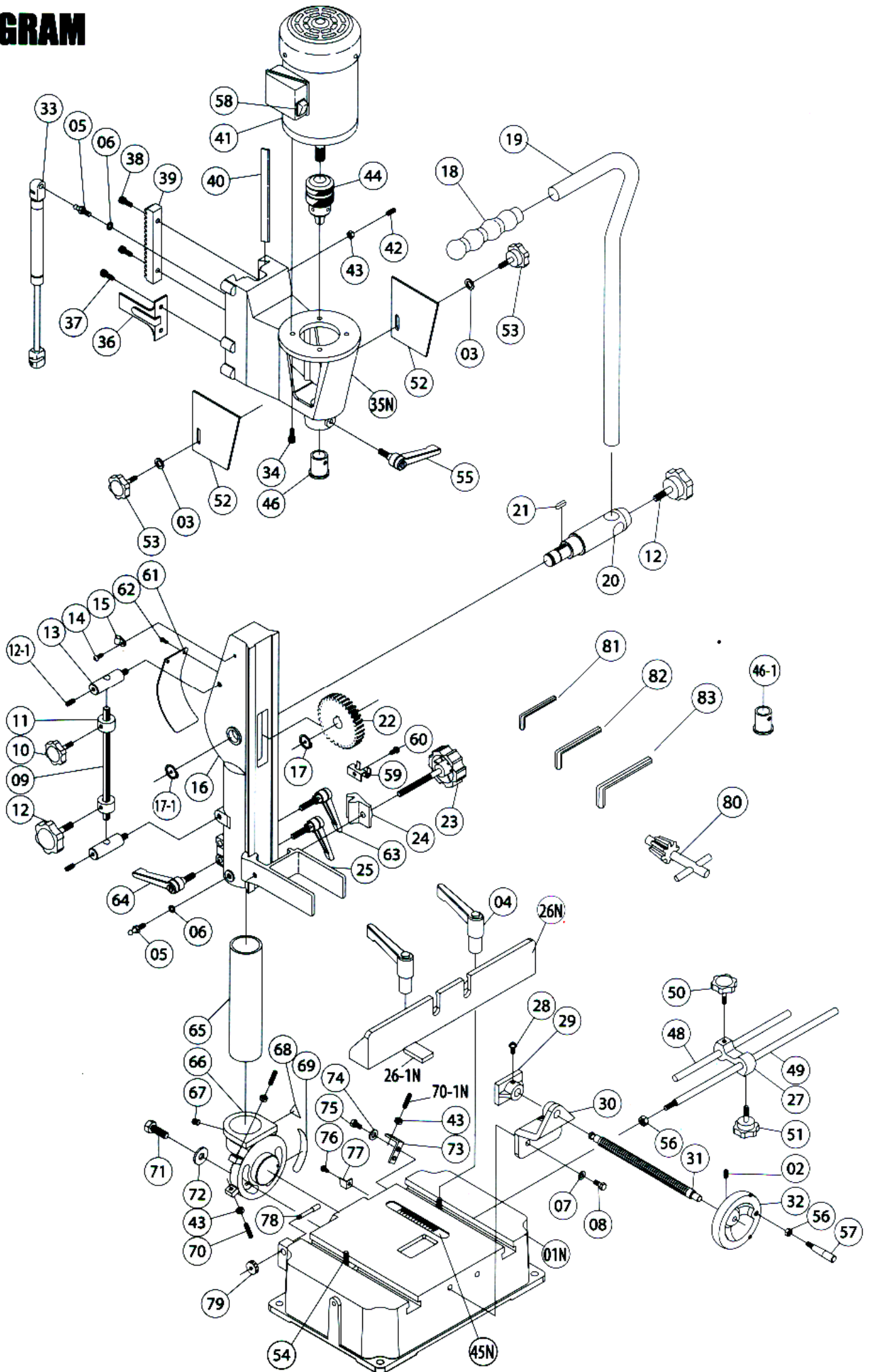

Parts List

| PART NO. | DESCRIPTION | QTY | PART NO. | DESCRIPTION | QTY |
|--------------|------------------------|-----|--------------|----------------------------|-----|
| 75050T-01N | BASE | 1 | 75050T-44 | CHUCK X 13 MM | 1 |
| 75050T-02 | SET SCREW 5/16 X 3/8 | 1 | 75050T-45N | SCALE | 1 |
| 75050T-03 | WASHER 1/4 | 2 | 75050T-46 | CHISEL BUSHING (5/8 SHANK) | 1 |
| 75050T-04 | RATCHET LEVER M8 | 2 | 75050T-46-1 | CHISEL BUSHING (3/4 SHANK) | 1 |
| 75050T-05 | SCREW M8 | 2 | 75050T-48 | STOP BAR (SHORT) | 1 |
| 75050T-06 | LOCK WASHER 3/8 | 2 | 75050T-49 | STOP BAR (LONG) | 1 |
| 75050T-07 | WASHER 5/16 | 2 | 75050T-50 | LOCK KNOB | 1 |
| 75050T-08 | HEX HEAD BOLT 5/16 X 1 | 2 | 75050T-51 | LOCK KNOB | 1 |
| 75050T-09 | DEPTH STOP BAR | 1 | 75050T-52 | SLIDE PLATE (CHUCK COVER) | 2 |
| 75050T-10 | LOCK KNOB 5/16 X 3/4 | 1 | 75050T-53 | LOCK KNOB 1/4 | 2 |
| 75050T-11 | ADJUSTING SLEEVE | 2 | 75050T-54 | BOLT M 8 | 2 |
| 75050T-12 | LOCK KNOB 5/16 | 2 | 75050T-55 | RATCHET LEVER | 1 |
| 75050T-12-1 | SET SCREW 5/16 X 3/8 | 2 | 75050T-56 | NUT 5/16 | 2 |
| 75050T-13 | STOP BAR SUPPORT POST | 2 | 75050T-57 | HANDLE | 1 |
| 75050T-14 | SCREW 3/16 | 1 | 75050T-58 | SWITCH | 1 |
| 75050T-15 | CORD CLAMP 1/4 | 1 | 75050T-59 | CHUCK KEY HOLDER | 1 |
| 75050T-16 | COLUMN | 1 | 75050T-60 | SCREW 3/16 | 1 |
| 75050T-17 | "C" RING 15 | 1 | 75050T-61 | GEAR COVER | 1 |
| 75050T-17-1 | "C" RING 20 | 1 | 75050T-62 | SCREW | 2 |
| 75050T-18 | HANDLE GRIP | 1 | 75050T-63 | RATCHET LEVER 5/16 | 2 |
| 75050T-19 | DOWNFEED HANDLE | 1 | 75050T-64 | RATCHET LEVER M6 | 1 |
| 75050T-20 | DOWNFEED SHAFT | 1 | 75050T-65 | COLUMN EXTENSION POST | 1 |
| 75050T-21 | KEY | 1 | 75050T-66 | COLUMN MOUNT BRACKET | 1 |
| 75050T-22 | GEAR | 1 | 75050T-67 | SET SCREW | 2 |
| 75050T-23 | LOCK KNOB 3/8 X 90 | 1 | 75050T-68 | LABEL | 2 |
| 75050T-24 | HOLD DOWN CLAMP ARM | 1 | 75050T-69 | ANGLE SCALE | 1 |
| 75050T-25 | HOLD DOWN CLAMP ARM | 1 | 75050T-70 | SET SCREW | 2 |
| 75050T-26N | FENCE | 1 | 75050T-70-1N | SET SCREW M6X25 | 1 |
| 75050T-26-1N | SLIDE BAR | 1 | 75050T-71 | HEX HEAD BOLT | 2 |
| 75050T-27 | STOP BAR BLOCK | 1 | 75050T-72 | FLAT WASHER | 4 |
| 75050T-28 | SCREW 1/4 X 5/8 | 1 | 75050T-73 | TILT STOP BRACKET | 1 |
| 75050T-29 | WISE PLATE | 1 | 75050T-74 | FLAT WASHER | 2 |
| 75050T-30N | WISE MOUNT BRACKET | 1 | 75050T-75 | HEX HEAD BOLT | 2 |
| 75050T-31 | THREADED ROD | 1 | 75050T-76 | SCREW | 1 |
| 75050T-32 | HANDWHEEL | 1 | 75050T-77 | POINTER | 1 |
| 75050T-33 | GAS SPRING | 1 | 75050T-78 | STOP PIN | 1 |
| 75050T-34 | CAP SCREW 1/4 X 1 | 4 | 75050T-79 | NUT | 1 |
| 75050T-35N | MACHINE HEAD | 1 | 75050T-80 | CHUCK KEY | 1 |
| 75050T-36 | STOP PLATE | 1 | 75050T-81 | 3 MM ALLEN KEY | 1 |
| 75050T-37 | CAP SCREW 1/4 X 3/4 | 2 | 75050T-82 | 4 MM ALLEN KEY | 1 |
| 75050T-38 | CAP SCREW 1/4 X 5/8 | 2 | 75050T-83 | 5 MM ALLEN KEY | 1 |
| 75050T-39 | RACK | 1 | | | |
| 75050T-40 | SLIDE PLATE | 1 | | | |
| 75050T-41 | MOTOR | 1 | | | |
| 75050T-42 | SET SCREW 5/16 X 3/4 | 3 | | | |
| 75050T-43 | HEX NUT 5/16 | 3 | | | |